

# FOR CYLINDRICAL GRINDING MACHINES AND LATHES

## Full centres with large carbide insert alike to DIN 806 E

Order No.	Cone	D <sup>ø</sup>	d <sub>2</sub> <sup>ø</sup>	l <sub>1</sub>	L
V 112	MK 2	11	18	36	100
V 142	MK 2	14			
V 182	MK 2	18			
V 143	MK 3	14	24,1	44	125
V 183	MK 3	18			
V 253	MK 3	24,1			
V 184	MK 4	18	31,6	57,5	160
V 254	MK 4	25			
V 304	MK 4	31,6			
V 255	MK 5	25	44,7	70,5	200
V 305	MK 5	30			
V 355	MK 5	35			
V 405	MK 5	44,7	63,8	88	270
V 256	MK 6	25			
V 306	MK 6	30			
V 356	MK 6	35	63,8	88	270
V 406	MK 6	40			
V 506	MK 6	50			
V 606	MK 6	63,8			

## Centres with large carbide ring alike to DIN 806 E

Order No. Form A	Order No. Form B	Cone	D x d	l <sub>1</sub>	L
AA 252	AB 252	MK 2	25 x 12	40	104
AA 302	AB 302	MK 2	30 x 16		
AA 352	AB 352	MK 2	35 x 20		
AA 402	AB 402	MK 2	40 x 24	45	109
AA 462	AB 462	MK 2	46 x 28		
AA 502	AB 502	MK 2	50 x 30		
AA 253	AB 253	MK 3	25 x 12	45	125
AA 303	AB 303	MK 3	30 x 16		
AA 353	AB 353	MK 3	35 x 20		
AA 403	AB 403	MK 3	40 x 24	50	130
AA 463	AB 463	MK 3	46 x 28		
AA 503	AB 503	MK 3	50 x 30		
AA 254	AB 254	MK 4	25 x 12	55	157
AA 304	AB 304	MK 4	30 x 16		
AA 354	AB 354	MK 4	35 x 20		
AA 404	AB 404	MK 4	40 x 24	60	162
AA 464	AB 464	MK 4	46 x 28		
AA 504	AB 504	MK 4	50 x 30		
AA 604	AB 604	MK 4	60 x 40	70	199
AA 255	AB 255	MK 5	25 x 12		
AA 305	AB 305	MK 5	30 x 16		
AA 355	AB 355	MK 5	35 x 20	70	199
AA 405	AB 405	MK 5	40 x 24		
AA 465	AB 465	MK 5	46 x 28		
AA 505	AB 505	MK 5	50 x 30		
AA 605	AB 605	MK 5	60 x 40		

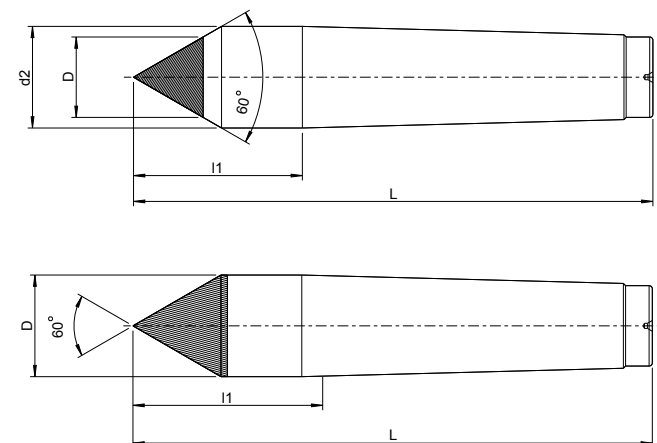

Form A, without draw-off thread

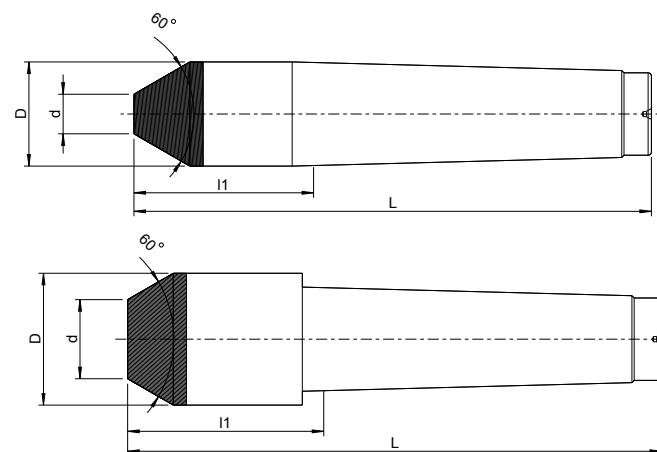

Form B, with draw-off thread

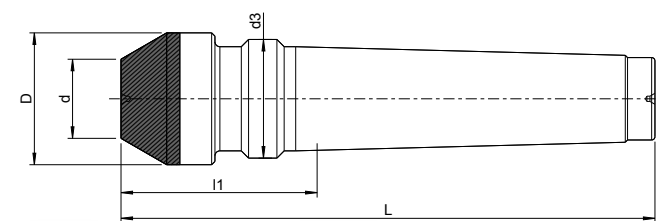

Dead centres with other point angle or extended version on request.